

Wish Installation Accessories

Output Multiplexers



The objective of the output multiplexers is to allow that several Gap-fillers share an only transmitting antenna, providing high isolation –and therefore null influence between them-, and eliminating the transmitter harmonic interference and, as far as possible, the out of band intermodulation.

The use of 5-pole comb-line filters guarantees to be able to multiplex with only one guard channel.

STAR POINT Multiplexers (5 poles)

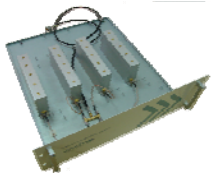

The **Star Point** multiplexers are made up of 2, 3 or 4 filters connected to a common point (diplexer, triplexer or tetra-plexer respectively) by means of transmission lines of different lengths.

These lengths are calculated and optimized by means of software to achieve the best impedance matching and isolation between ports, and the best possible answer in transmission.

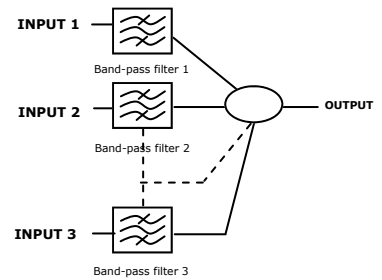

MANIFOLD Multiplexers (5 poles)



The **Manifold** multiplexers are made up of 2, 3 or 4 filters connected in parallel to a common transmission line, with a short circuit at one end and the system output at the other end.

The correct impedance matching, transmission and isolation between ports is achieved thanks to the position of the filters along the transmission line and to the distance to the short circuit.

All these distances are calculated and optimized by means of software. The performances are similar to those achieved with the Star point topology. Nevertheless, they offer a bit better impedance matching and a more compact arrangement inside the rack tray.

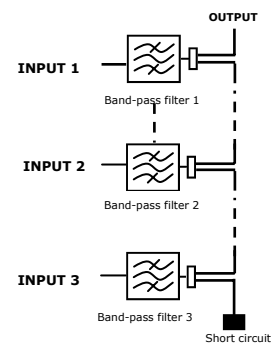

CONSTANT IMPEDANCE Multiplexers (5 poles)

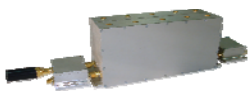

A **Constant Impedance** multiplexer is composed of the cascade connection of the basic cell that consists of two 3 dB branch line couplers, two identical band-pass filters and a load of 50 Ω , in accordance with the figure 1.

This type of multiplexers offers high isolation between ports and better impedance matching and transmission than the other topologies (Star Point and Manifold).

Because of the fact that this configuration has a 3 dB branch line coupler that divide the signal in the input, it offers better performances from medium to high power levels than the rest of topologies.

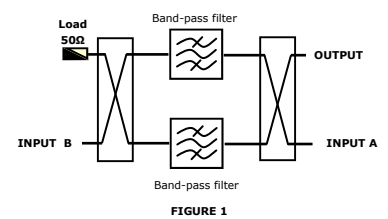
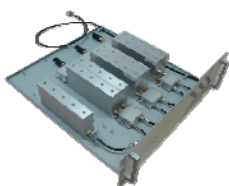

FIGURE 1



Moreover, thanks to this topology is independent of transmission lines of different lengths, if we want to transpose the frequency channel, we will only need to change the filters without having to calculate any other length again.

If the basic cell is connected like it is indicated in figure 2, we will be able to multiplex up to 4 channels.

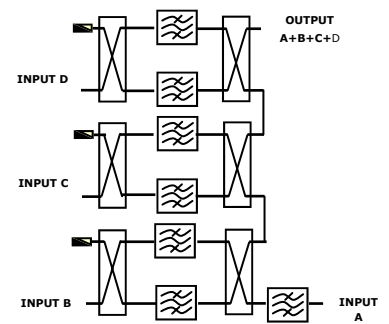

FIGURE 2

Technical Specifications

5-pole STAR POINT Multiplexers			
Identifier	WSDISP5P	WSTRISP5P	WSTESP5P
Configuration		Star Point (5 poles)	
Frequency range		470 - 862 MHz	
Bandwidth		8 MHz	
Number of channels	2	3	4
Impedance		50Ω	
I/O Matching		20 dB	
Insertion loss at f(0)	2 dB	2,5 dB	3 dB
Ripple		0,2 dB	
Isolation between ports		40 dB	
Minimum separation between channels		1 channel (8 MHz)	
Selectivity (f(0)±12 MHz)		35-40 dB	
Maximum input power		5 W DVB-T— 20 W (analogical)	
Input connectors		SMA female	
Output connector		SMA male	
Dimensions		3 units high in 19" rack	

5-pole MANIFOLD Multiplexers			
Identifier	WSDIMF5P	WSTRIMF5P	WSTEMF5P
Configuration		Manifold (5 poles)	
Frequency range		470 - 862 MHz	
Bandwidth		8 MHz	
Number of channels	2	3	4
Impedance		50Ω	
I/O Matching		20 - 25 dB	
Insertion loss at f(0)	2 dB	2,5 dB	3 dB
Ripple		0,2 dB	
Isolation between ports		50 dB	
Minimum separation between channels		1 channel (8 MHz)	
Selectivity (f(0)±12 MHz)		35-40 dB	
Maximum input power		5 W DVB-T— 20 W (analogical)	
Connectors		SMA female	
Dimensions		3 units high in 19" rack	

5-pole CONSTANT IMPEDANCE Multiplexers			
Identifier	WSDIIC5P	WSTRIIC5P	WSTEIC5P
Configuration		Constant Impedance (5 poles)	
Frequency range		470 - 862 MHz	
Bandwidth		8 MHz	
Number of channels	2	3	4
Impedance		50Ω	
I/O Matching		25-30 dB	
Insertion loss at f(0)	2 dB	2,4 dB	2,8 dB
Ripple		0,2 dB	
Isolation between ports		50 dB	
Minimum separation between channels		1 channel (8 MHz)	
Selectivity (f(0)±12 MHz)		40 dB	
Maximum input power		10 W DVB-T— 40 W (analogical)	
Connectors		SMA female	
Dimensions		3 units high in 19" rack	